

Ordering Information:  
 C6201F - \*\*\* - E - H - \*\*\*  
 1            2            3

1. Part NO.
2. Material:  
 GP: Phosphor Bronze  
 GCA: High conductive copper alloy
3. Finish:  
 (Blank): Gold over Nickel (Au:1u")  
 G10: Gold over Nickel (Au:10u" Mating area)  
 G15: Gold over Nickel (Au:15u" Mating area)  
 G30: Gold over Nickel (Au:30u" Mating area)

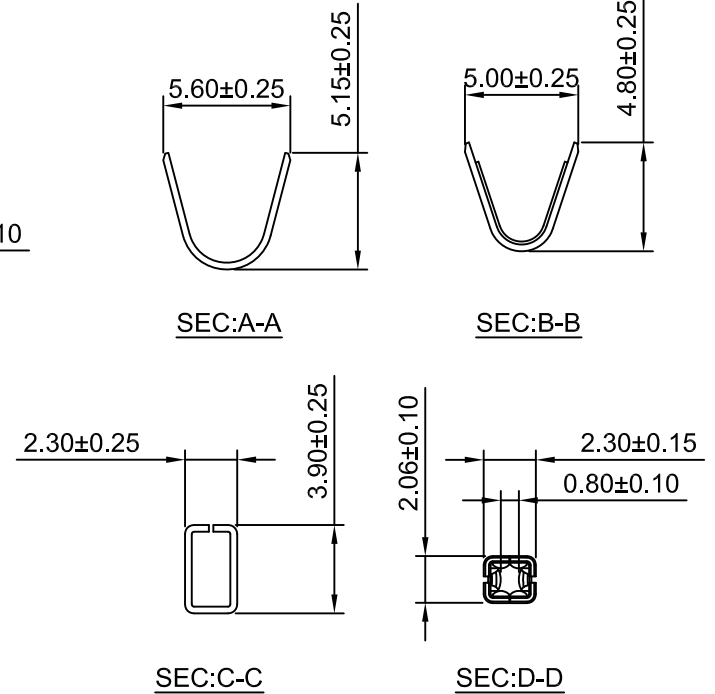
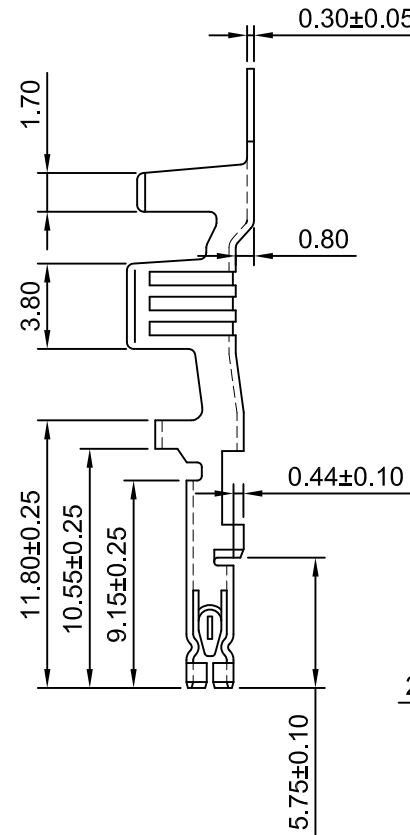
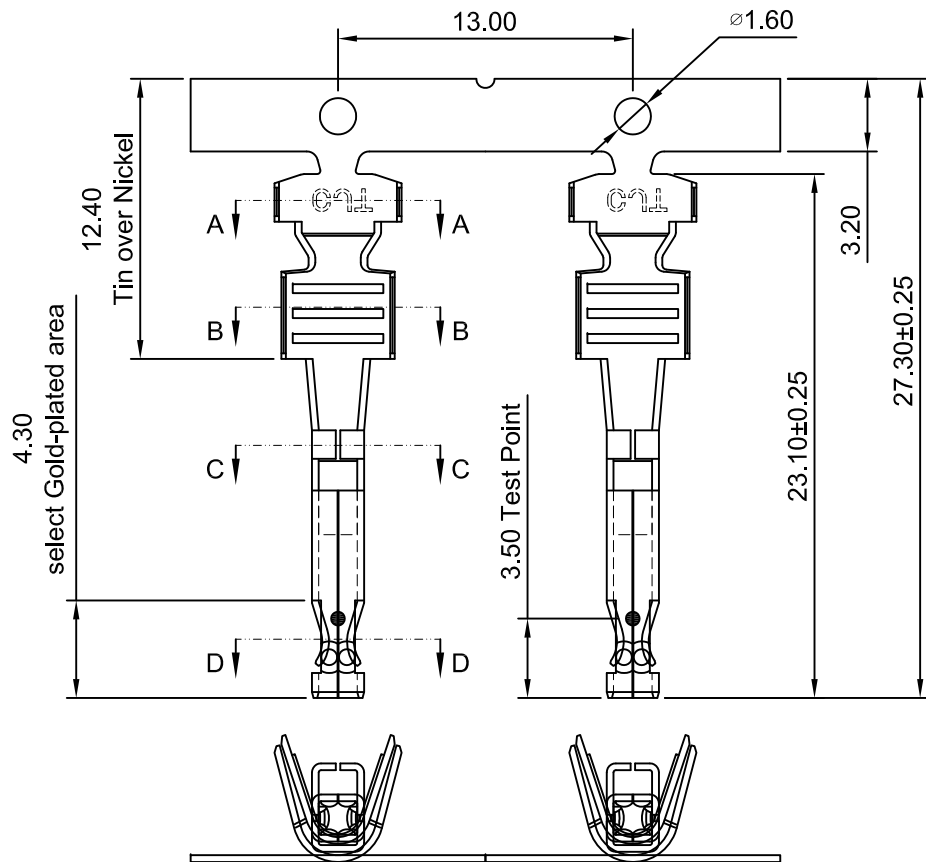

Ordering information & Specifications

Unit:mm

Part NO.	Wire Range	Insultion O.D.	Material	Finish	Qty/reel
C6201F-TP-E-H	AWG#12	4.35mm(max)	Phosphor Bronze	Tin over Nickel	2,000 PCS
C6201F-GP-E-H	AWG#12	4.35mm(max)	Phosphor Bronze	Gold over Nickel	2,000 PCS
C6201F-TCA-E-H	AWG#12	4.35mm(max)	High conductive copper alloy	Tin over Nickel	2,000 PCS
C6201F-GCA-E-H	AWG#12	4.35mm(max)	High conductive copper alloy	Gold over Nickel	2,000 PCS



**CJT** CHANGJIANG CONNECTORS CO.,LTD.

Unit	Scale	Sheet	TITLE
mm	3:1	1 of 2	5.70mm PITCH CRIMP TERMINAL
DRWN	CHK'D	APPR	
Wenmin Luo	Diankui Wan	Jack Yin	
General Tolerances			THIRD ANGLE PROJECTION
x.xx±0.25 x.xxx±0.20 x.xxxx±0.15 ANGLES ±1°			DRAWING NO.
			C6201F-T-E-H
REV			DESCRIPTION
DATE			REV
			A2

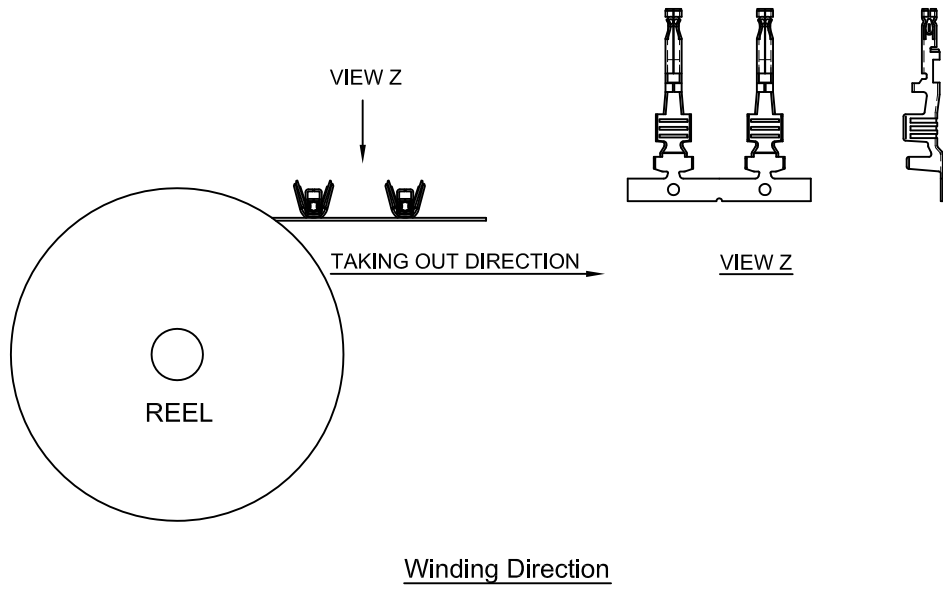
REV	DESCRIPTION	DATE
A2	MODIFY DRAWING	2023.01.04
A1	MODIFY DRAWING	2022.11.24
A0	NEW RELEASE	2020.12.20



REV	DESCRIPTION	DATE
A2	MODIFY DRAWING	2023.01.04
A1	MODIFY DRAWING	2022.11.24
A0	NEW RELEASE	2020.12.20

 <b>CHANGJIANG CONNECTORS CO.,LTD.</b>			TITLE	
			<b>5.70mm PITCH CRIMP TERMINAL</b>	
Unit	Scale	Sheet	DRAWING NO.	
mm	3:1	2 of 2		
DRWN	CHK'D	APPR	<b>C6201F-T-E-H</b>	
Wenmin Luo	Diankui Wan	Jack Yin		
General Tolerances			THIRD ANGLE PROJECTION 	REV
x.xx±0.25 x.xxx±0.20 x.xxxx±0.15 ANGLES ±1°				